

Installation Instructions

DLED-126 Mesa Sconce with 10W COB-LED and DL-260 Box

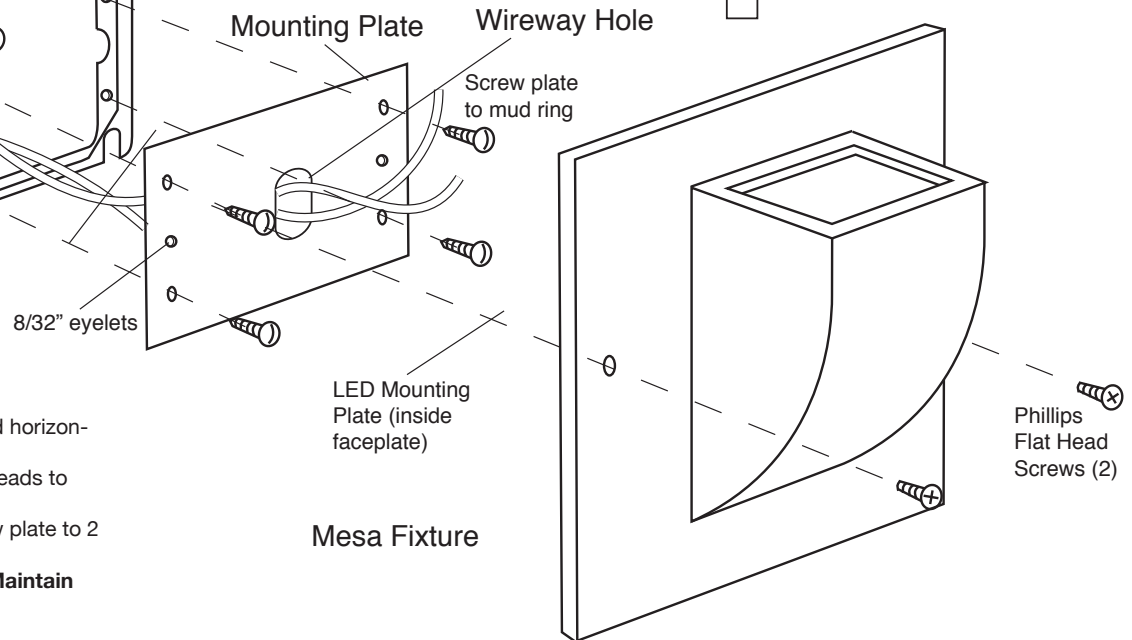
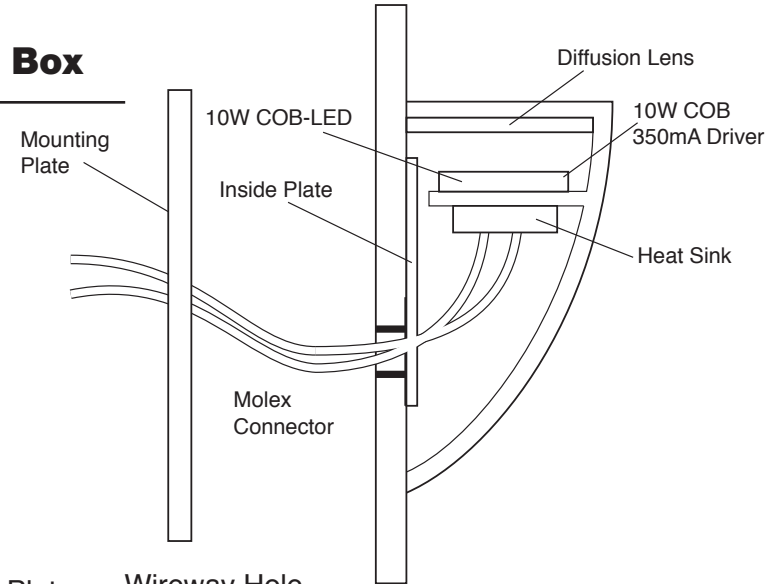
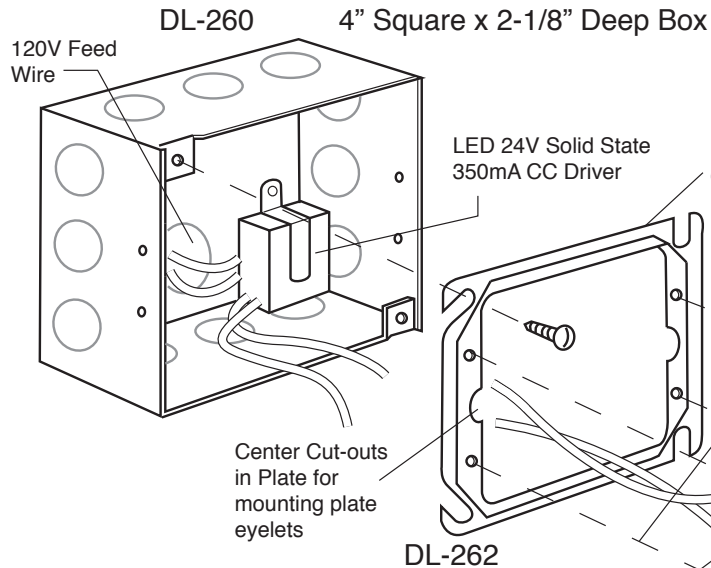

1. Install 4" sq. x 2-1/8" deep DL-260 box at fixture location.
2. Supply 90°C 110V feed wires to box.
3. Attach custom 2-gang mud ring mounting plate to box.
IMPORTANT: Center cut-out in mud ring mounting plate must be aligned horizontally to accept horizontal eyelets in mounting plate.
4. Secure 350mA driver inside box with bracket. Attach 120V high voltage leads to 120V leads on driver. Ground fixture per NEC requirements.
5. Push low voltage leads from driver through hole in mounting plate. Screw plate to 2 gang mud ring.
6. Splice LV wire from driver to wire attached to COB LED. **IMPORTANT: Maintain polarity. Plus to plus and minus to minus.**
7. Feed LV wire back into box through hole in mounting plate.
8. Screw Mesa casting to mounting plate with the two 8/32 flat head screws supplied.
9. Supply 350mA driver with correct input voltage.

Dimmable with Reverse Phase with Neutral.

dreamscape
LIGHTING MFG., INC.

©Dreamscape Lighting Mfg., Inc.
5Phone: 323-933-5760
info@dreamscapelighting.com • www.dreamscapelighting.com

• Specifications subject to change without notice



DLED-126-10WCOB_Inst_01_25_22