

Project:

DLED-45 SERIES SPECIFICATION SHEET

Aria LED Post Light with Dual Lenses

Date:

Type:

Cat. No: DLED-45 _____ + _____ + _____ + _____ + _____

Fixture Description:

The Aria LED Post Light is an elegant contemporary accent light that provides a striking visual image. It uses an energy efficient wet location LED light source.

Construction:

Intersecting acrylic and extruded aluminum panels create the Aria Post light form. The LED light channel is encased inside a wet location mounting tube that provides the light source.

3. Electrical:

24 Volts AC. 2.5W (X2) per foot. Color temp: 2700K, 3000K.

3 year warranty.

Options:

Dual light output standard. Single light output optional. Back shield optional.

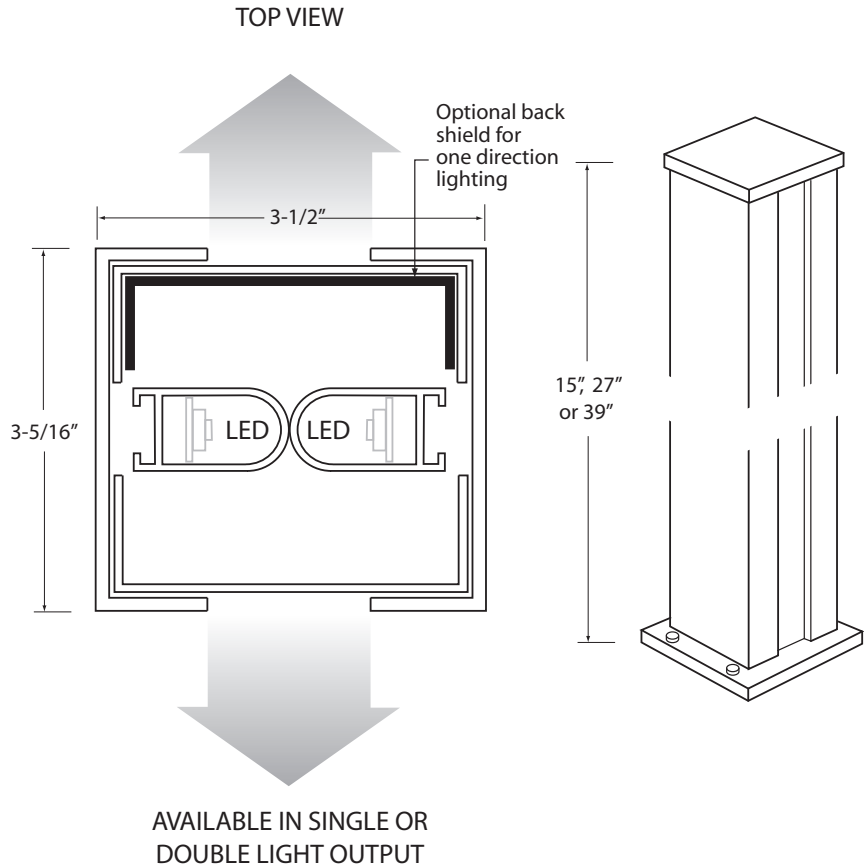

Model No.	Length	Double or Single Light	Finish	Optional Back Shield	Color Temp.
DLED-45	15", 27", 39"	DBL (2 - LED strips) SGL (1 - LED strip)	SA Satin Aluminum Clear Coat	BS	2700K
			BL Black		3000K
			WH White		