

LED 50,000 Hour Dimmable Light Strip for Dry Location 260 Lumens per Foot - 3.9 Watts per Foot - CRI 82+

PROJECT

TYPE

CATALOG NUMBER

Fixture Description: The DLED 5100 is a continuous line of dimmable LED's soldered to a rigid PC board. They have been designed to give a long consistent color over the 50,000 hr. lamp life, because of good thermal management of the SMD's and quality phosphors used in production. This LED light source provides a soft even glow at a huge energy savings over incandescent or halogen. The 50,000 hr. lamp life greatly reduces maintenance.

Construction: 16 LED diodes per foot soldered to a rigid PC board with jumper wire and feed wire pre-wired and attached. For lengths from 75" to 96", two strips are connected by a 1" flex wire joiner.

Electrical: 24 Volt AC. 3.9 Watts per foot. 260 lumens per foot. CRI 82+. Dimmable.

IMPORTANT: LED strips are to be fed from UL Listed Class II magnetic transformers or Lutron Constant Voltage Drivers.

Mounting: Mounts into coves or other surfaces with screws and/or double stick tape.

Applications:

- Coves • Light Pockets • Accent Lighting
- Cabinet Lighting • Reveal Molding

Warranty: 5 years or 50,000 hours. See ambient temperature note in table below.

NOTE: Dimmers used must be approved for magnetic loads and use direct current or voltage regulation, such as Lutron Diva Series. Dimmers that use phase forward dimming technology must have a neutral. Check with factory for compatibility.

Please consult our website for any updated specifications on this product:
www.dreamscapelighting.com

LED Specifications

Voltage	24V AC
Watts	3.9W per foot
Lumens per Foot	260
Color Temperature	2700K, 3000K, 3500K
CRI	82+
Beam Spread	120°
Maximum Run	8'
Maximum Single Length	6'
Mounting	Screw or double stick tape
Warranty	5 years / 50,000 hours (in an environment that reaches no higher than 60°C / 140°F) NOTE: Please contact factory regarding warranty if fixture is exposed to higher ambient temperatures.

Secondary Wire Spec

Maximum Load	50W
Maximum Distance	50 feet
Wire	16AWG 2/C Type CM-CL2 ETL-CM CL3 Standard copper conductor

Connectors

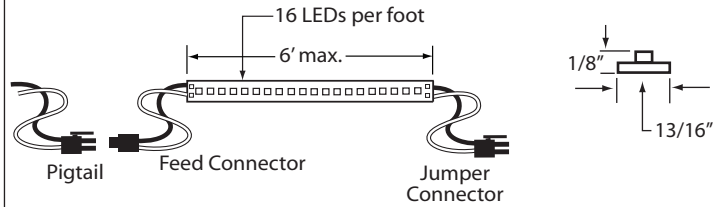

2 Separate Lengths Joined with 1" Flex Wire for LED Strips from 75" - 96"

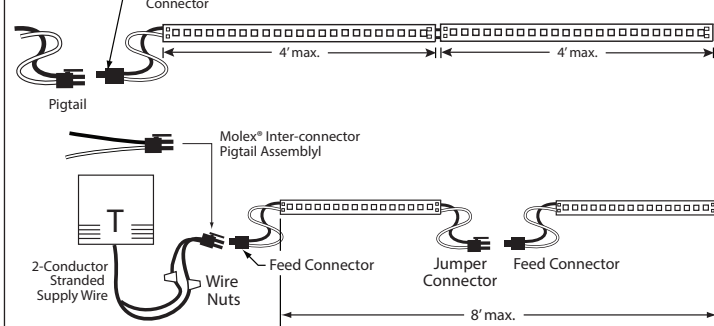

Cove Example

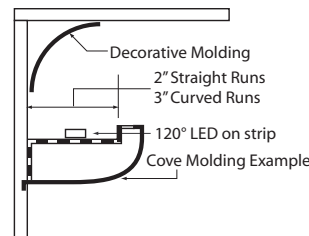

Light Pocket Example

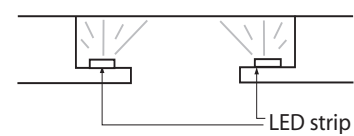

DL-CFB-5100 Conduit Feed Box

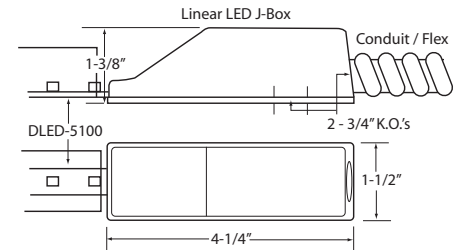

Model Number	LED Length	Feed Wire Length (F)	Jumper Wire Length (J)	Pigtail Length (P)	Color Temp.
DLED-5100	3", 6", 9", 12", 15", 18", 21", 24"	1.5", 3", 6", 12"	None* (0), .75"	0, 3", 12", 36"	2700K
	27", 30", 33", 36", 39", 42", 45", 48"	18", 30", CUSTOM	1.5", 3", 6", 12"	CUSTOM	3000K
	51", 54", 57", 60", 63", 66"		18", 30", CUSTOM		3500K
See NOTE above for LED lengths above 72"					
	75", 78", 81", 84", 87", 90", 93", 96"				

Ordering Example: **DLED-5100-12"-F3"-J3"-P3"-3000**

NOTE: All LED lengths 75" - 144" are made up of 2 separate units joined together by a 1" flex wire. FOR CURVILINEAR APPLICATIONS - SPECIFY .75" *JUMPER LENGTH You can specify "0" for no jumper wire on end. **PIGTAIL LENGTH: 1 pigtail per run (specify 3", 12", 36" or Custom).